

The logo for MURIDEO features a stylized letter 'M' composed of three overlapping triangles in shades of blue and purple. The word 'MURIDEO' is written in a bold, black, sans-serif font, centered horizontally and partially overlaid by the 'M' graphic.

MURIDEO

Fresco SIX-G

The NEXT Generator

Who Is Murideo?

Murideo was created out of the need to bring more modern tools to the CI Market. With a depth of knowledge brought on from years of experience in the electronics industry, we are hell bent on bringing cutting edge tools to the world at large that were previously only available to select groups.

Our Pledges Are Simple:

1. Focus On Technology
 2. Focus On Design
 3. Focus On User's
-

What we do.

Murideo is a manufacturer of goods designed to assist in calibration an installation to achieve incredible results and accuracy as it pertains to video distribution systems and calibration. We promise to only bring the most forward thinking products to the marketplace. Murideo releases only unique and previously unattainable items. If you are looking for "me too" products you're in the wrong place.

Our Products Include:

- Reference field generators
 - Analyzers (Coming soon)
 - Video Processors
-

What is the “SIX-G”?

The Murideo SIX-G is for the AV integration market to confirm HDMI 2.0 and HDCP 2.2 operation at the 18 GBPS level. Additionally, the SIX-G is an excellent troubleshooting tool for distributed HDMI systems and a reference source for video calibration and is compatible with CalMAN.

One of the biggest challenges for integrators today is determining what infrastructure to put in the systems they design and further verifying that all of the components will work together.

The SIX-G solves this problem.



Key Features:

- HDMI 2.0(a)
- 18 GBPS
- Full 4K60 4:4:4 output
- HDCP 2.2 On/Off
- EDID Read
- Long-Life Battery
- Handheld, optimized ergonomics
- Made for the field
- More Patterns
- ISF Certified
- DPL Labs Certified
- Reference Status Award



Front Panel:

Along with the next gen output, the Fresco SIX-G is designed to be robust in the field. The front panel gives you control of:

- Timing/Resolution
- Color Space & Deep Color
- HDCP Settings
- RGB Triplet & APL
- Read & Store Multiple EDID
- Audio Sample Size/Rate
- And More!



Making Connections:

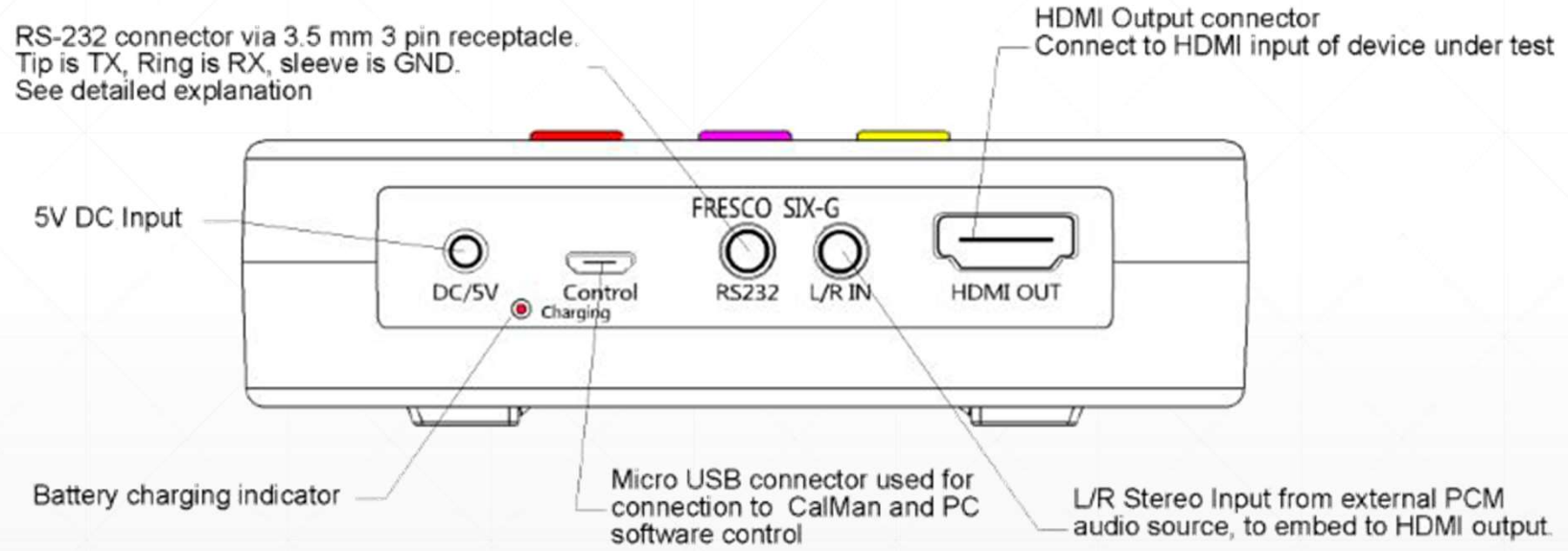

Controlling the Generator:

- Robust Front Panel Control
 - Free PC Control Software
 - CalMAN Calibration Software
-

A large, stylized letter 'M' composed of three overlapping triangles in shades of blue and grey, positioned behind the text.

MURIDEO

Fresco SIX-G

Practical Applications

Think in terms of GBPS, not just resolutions!

Once you understand GBPS and how it correlates to connectivity products in the current landscape, you can easily prepare, troubleshoot, and install future proof systems. Why GBPS?

- Too many variables with resolutions
- Resolution is quickly becoming a marketing term
- Most devices that are “4K” are actually “Faux K”

4K “Modes”	Content?	6 GBPS	9 GBPS	10.2 GBPS	18 GBPS
4K 30 (4:2:2)	Not Standard	x			
4K 30 (4:4:4)	None		X		
4K 60 (4:2:0)	Max HDBaseT			X	
4K 60 (4:4:4)	Nvidea, Blu-Ray				X

Did you know?!? Some products that exist advertise 4K but are less than 6 GBPS capable. While technically true, this does not do justice with actual 4K content! Imagine if an HDMI cable company advertised that throughput!

With the SIX-G, you don't have to guess.... ...you know!

Even if you understand this, not everyone does! Even if you do the legwork & research, you still may have components that are mismatched or misrepresented. So throw the charts away!

With the SIX-G you have:

- Reference Certified Source
- KNOWN Good Output
- Ability to truly gauge performance
- Ability to identify the “culprit” instead of “pull & pray”

4K “Modes”	Content?	6 GBPS	9 GBPS	10.2 GBPS	18 GBPS
4K 30 (4:2:2)	Standard				
4K 30 (4:4:4)	None		X		
4K 60 (4:2:0)	Max HDBaseT			X	
4K 60 (4:4:4)	None, Full Ray				X

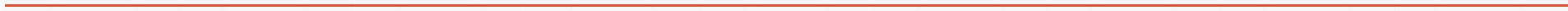
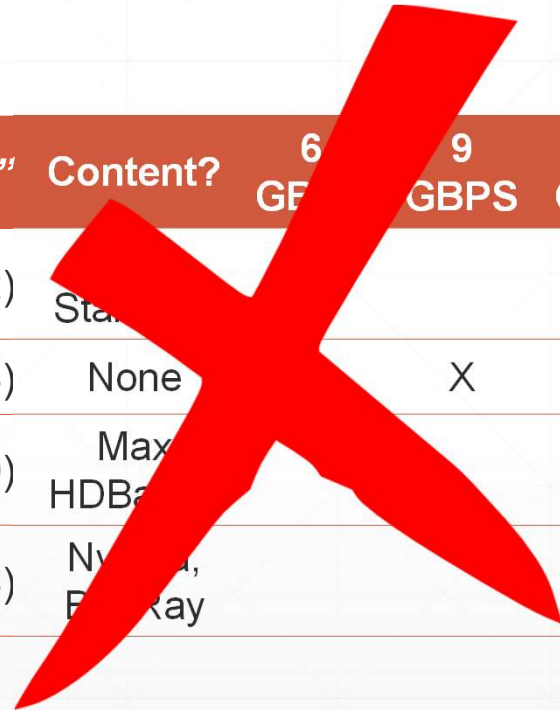

Fresco SIX-G Applications: Practice POV!

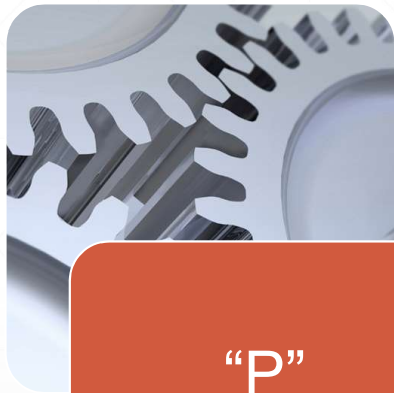

“P”
Pre-Installation
Checks



“O”
On-Site
Troubleshooting



“V”
Verification &
Calibration



Pre-Installation Checks

Things you can check with the SIX-G

- HDCP Version Conformity
- Maximum Signal Accepted/Passed
- EDID preference
- Audio Accepted/Passed
- Geometry/Distortion
- Optimal device for final decoding
- PC/VESA Compatibility

Devices you should be checking

- Display's, Display's, Display's!
 - Extenders/Baluns
 - Switches
 - Distribution Amps
 - HDMI Cables (Length Matters!)
 - HDIP
 - Anything that you use to move HDMI around.
-

On-Site Troubleshooting

Why do On-Site Troubleshooting with the SIX-G?

- Pin-point problem component.
- No need to “pull & pray”.
- Save valuable time on support calls
- Save money on repeat visits to replace parts.
- Identify shortcomings
- Verify compatibility
- HDCP Compliance through a system

5 Step Problem component discovery

1. Start at the source and inject desired signal through path (HDCP, Desired Resolution, etc...)
2. Verify picture on Sync/Display
3. Move generator to next device in chain
4. Repeat
5. Once you have passed the problem component, you will see the desired image.

Now that you have found the problem component, verify settings on that device or replace. Reinject signal to verify.

Verification & Calibration

System performance verification is often overlooked. With the SIX-G, this step is now very simple and save headaches in the future!

- Verify the total system passes highest desired resolution.
- Verify the total system passes HDCP 1.4/2.2
- Verify frame geometry/image distortion
- Verify PC resolutions if in a class/conference room
- Verify fluid vertical & horizontal motion
- Verify Audio passes through the system
- Leave job feeling worry free!

Display calibration is also often overlooked. The SIX-G is designed to assist in calibration at varying degrees.

- Set brightness and contrast to achieve uniformity for commercial applications.
 - Set proper aspect ratios
 - Calibrate accurate greyscale
 - Pin-point Color Management Systems jaw dropping color.
 - The SIX-G is ISF Certified meaning, the black, white and colors output from the device exactly replicate the industry accepted color space conversions.
 - For more on calibration visit www.murideo.com or www.avpro.training for classes.
-

Connection Diagram
Fresco SIX-G

TYPICAL SYSTEM DIAGRAM



Use the SIX-G to test for resolution mismatch, color space error and HDCP error by injecting known good reference pattern into signal path.

Connection Diagram
Fresco SIX-G

TEST DISPLAY

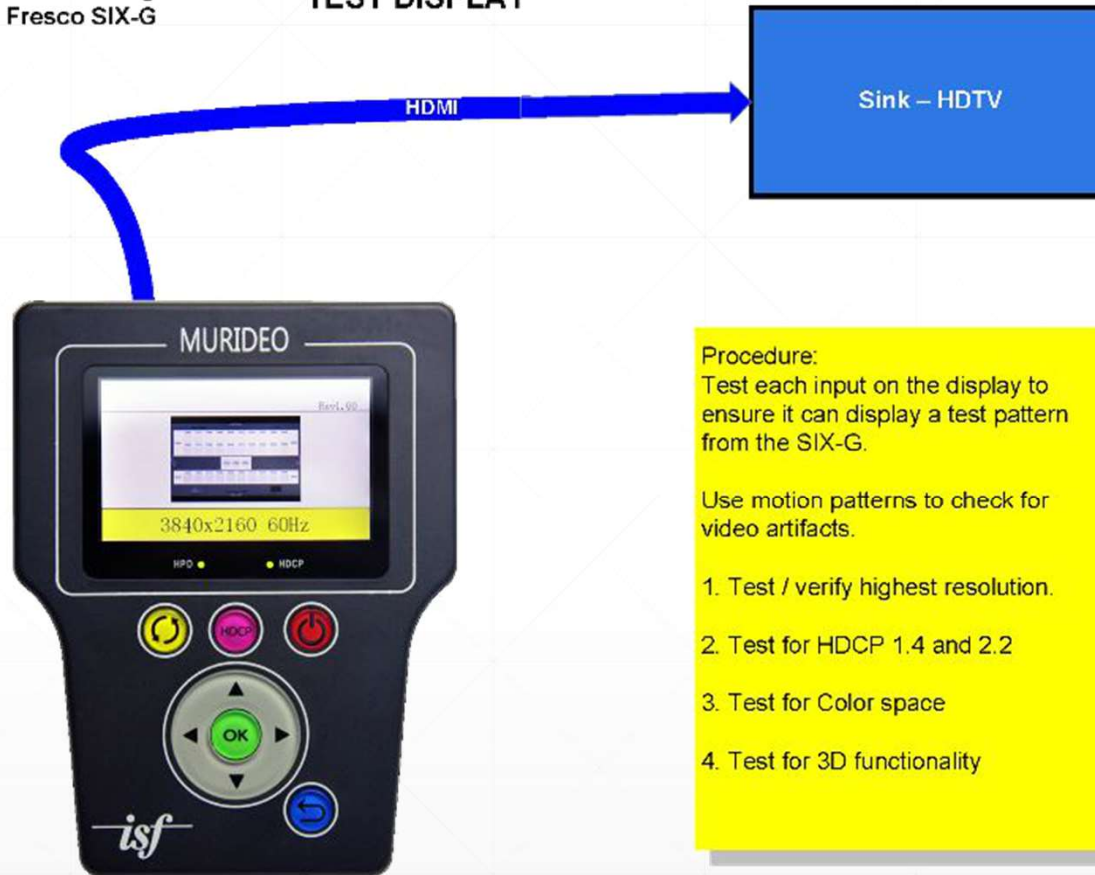

Procedure:
Test each input on the display to ensure it can display a test pattern from the SIX-G.

Use motion patterns to check for video artifacts.

1. Test / verify highest resolution.
2. Test for HDCP 1.4 and 2.2
3. Test for Color space
4. Test for 3D functionality

Troubleshooting with the SIX-G - Inject known resolutions and timings into the suspect system. Lower the resolution until you can get a test pattern to appear. Test sink and repeater separately to determine while component is not passing the higher resolution and replace that component.

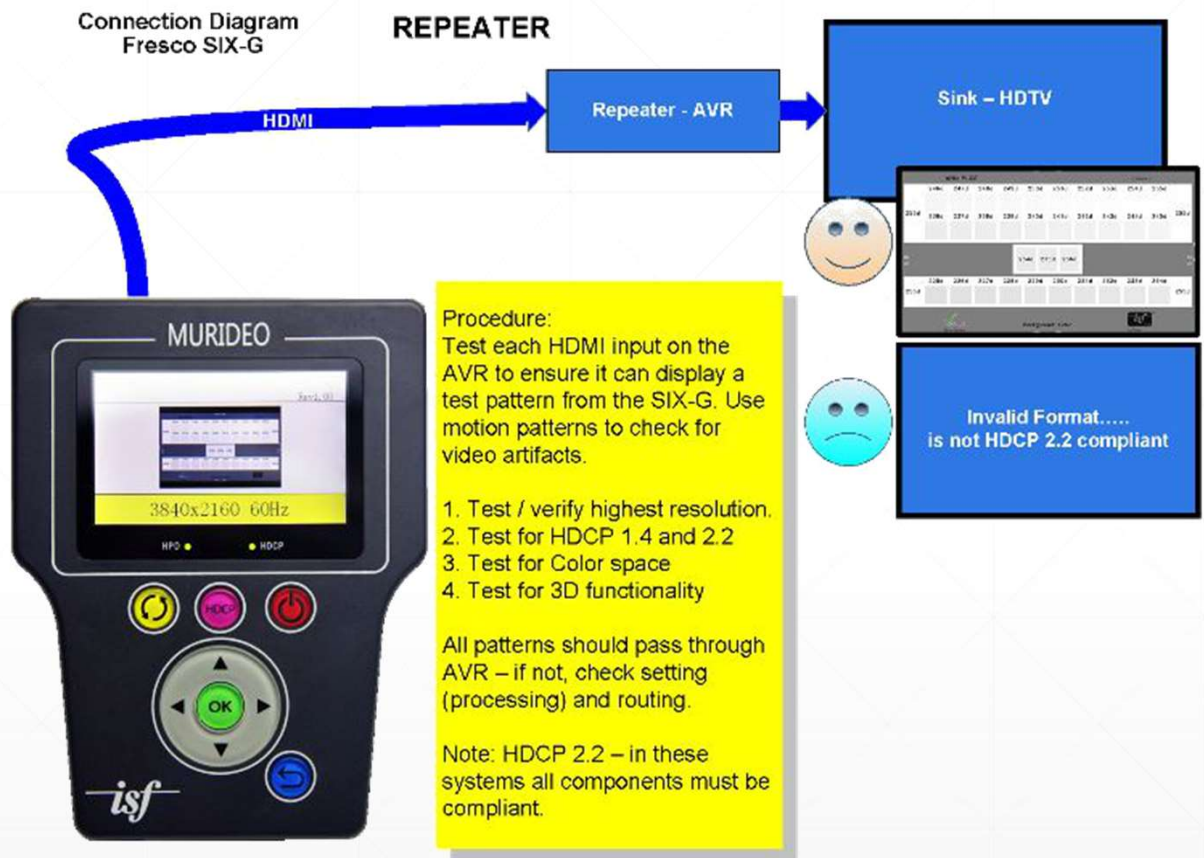

Troubleshooting with the SIX-G - Test all displays for maximum resolution and HDCP compliance.

Connection Diagram
Fresco SIX-G



DISTRIBUTED SYSTEM



Procedure:
Inject known good signal into the TX.
1. Test/verify highest resolution.
Note – when marginal CAT cables are used (ex. CCA) or there are faulty terminations full bandwidth signals will not pass.
You may need to select lower resolution to verify connection (ex. 720P).
2. Test for HDCP 1.4 and 2.2
3. Test for Color space
4. Test for 3D functionality

All patterns should pass through installed Extenders and AVR – if not, check setting (processing) and routing.
Check for bad terminations and long runs (exceed extender limit –
Note: the specs vary by resolution and length on HDBaseT lite chips (commonly called 70M)

When testing HDCP 2.2 – all components linked in the system must be compliant.

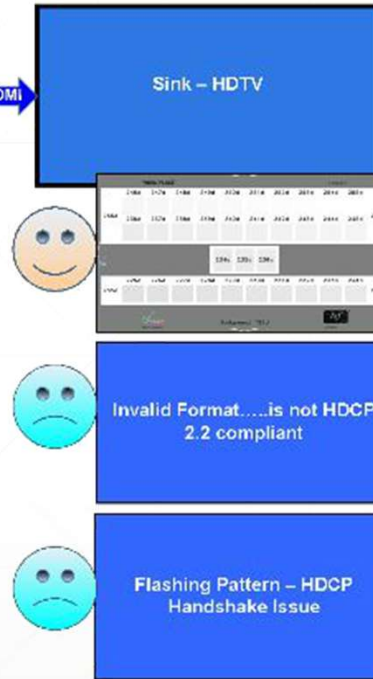

HDMI Tips For Installers

- Use Active equipment over Passive wherever possible
 - Insure all devices are on the most recent firmware
 - Insure all devices are on the same AC circuit if possible
 - Keep solid HDMI runs under 25ft (use 24AWG) and go to HDBaseT extenders for runs over 25'.
 - Use best cabling possible, the higher bandwidth the better.
 - CAT5e or better - use shielded (STP) when you are not absolutely sure what is behind the wall.
-

HDMI Tips For Installers Cont.

- Use only solid copper CAT cables - no CCA.
 - Don't over complicate the system with too many devices in series. Too many handshakes cause unexpected and unwanted results.
 - Try to buy all the HDMI devices and HDMI cables from one vendor as they have been tested with each other assuring system interoperability.
 - Cycle power on all devices in the system - this will cause a hot plug event and will cause the source to read the sink EDID again and possibly return the system to normal operation
 - Make sure everything in the system is HDCP 2.2 compliant in a UHD distribution system.
 - Clock stretching issues are common in some STB with older HDMI chipsets (although they look new). This will cause a no picture situation. You can use EDID minder to fix this, and some connectivity companies' even list a fix for clock stretching as a feature in extenders and matrix switches.
 - When using POE extenders - make sure they are IEEE 802.11af - this ensures that you don't damage downstream or upstream components.
-